

# MOD:XEBDC-02EU-D



## ENGLISH

## TECHNICAL DATA

- 01 POWER
- 03 FREQUENCY
- 04 POWER SUPPLY CABLE TYPE
- 05 EXTERNAL Ø OF POWER SUPPLY CABLE
- 06 VOLTAGE / POWER CABLE SECTION / CURRENT

5,4 kW  
50 / 60 Hz  
H07RN-F  
16 mm

380-400 V~3PH+N+PE  
5G x 1,5 mm<sup>2</sup>  
Circuit Breaker 16 A  
I1=12 A - I2=12 A - I3=0,5 A - In=12 A

230 V~3PH+PE  
4G x 2,5 mm<sup>2</sup>  
Circuit Breaker 25 A  
I1=20.5 A - I2=12 A - I3=12 A - In=

230 V~1PH+N+PE  
3G x 4 mm<sup>2</sup>  
Circuit Breaker 32 A  
I1=24 A - I2= - I3= - In=24 A

- 11 MAX FOOD LOAD
- 13 WATER MAX CONSUMPTION
- 02 NOMINAL HEAT INPUT
- 18 CAVITY DIMENSIONS ( W - D - H )
- 20 IP PROTECTION CLASS

5 kg  
0,9 l/h @ 200 kPa  
5,4 kW  
620x883x224 mm  
X4

## ITALIANO

- 01 POTENZA
- 03 FREQUENZA
- 04 TIPO DI CAVO ALIMENTAZIONE
- 05 Ø ESTERNO CAVO DI ALIMENTAZIONE
- 06 TENSIONE / SEZIONE CAVI ALIMENTAZIONE / CORRENTE
- 11 CARICA MAX CIBO
- 13 CONSUMO MAX ACQUA
- 02 POTENZA TERMICA NOMINALE
- 18 DIMENSIONI CAMERA COTTURA ( L - P - H )
- 20 GRADO PROTEZIONE IP

## FRANCAIS

- 01 PUISSANCE ELECTRIQUE
- 03 FREQUENCE
- 04 TYPE DE CABLE D'ALIMENTATION
- 05 Ø EXTERNE DU CABLE D'ALIMENTATION
- 06 TENSION / SECTION CABLE D'ALIM.
- 11 CHARGE MAXIMALE D'ALIMENT
- 13 CONSOMMATION MAX DE L'EAU
- 02 DEBIT THERMIQUE NOMINAL
- 18 DIMENSIONS CHAMBRE DE CUISSON ( L - P - A )
- 20 INDICE DE PROTECTION IP

## ESPAÑOL

- 01 POTENCIA
- 03 FRECUENCIA
- 04 TIPO DE CABLE DE ALIMENTACION
- 05 Ø CABLE EXTERNO DE ALIMENTACION
- 06 TENSION / SECCION CABLES DE ALIMENTACION
- 11 CARGA MAX. DE ALIMENTOS
- 13 CONSUMO MAX DE AGUA
- 02 POTENCIA TERMICA NOMINAL
- 18 DIMENSIONES CÁMARA DE COCCIÓN ( An - Pr - Al )
- 20 GRADO DE PROTECCION IP

## DEUTSCH

- 01 ELEKTRISCHE LEISTUNG
- 03 FREQUENZ
- 04 ZULEITUNGSKABELTYP
- 05 AUSSENDURCHMESSER DES VERSORGUNGSKABELS
- 06 KABELQUERSCHNITT UND VERSORGUNGSSPANNUNG
- 11 MAX. SPEISENFASSUNGSVERMOGEN
- 13 MAXIMUM WASSERVERBRAUCH
- 02 NOMINALE WARMELEISTUNG
- 18 GRÖÖBE DES KOCHKAMMERS ( B - T - H )
- 20 SCHTZART IP

# MOD:XEBDC-02EU-D



## ENGLISH - DRAWINGS

2	TERMINAL BOARD POWER SUPPLY
3	UNIPOTENTIAL TERMINAL
6	TECHNICAL DATA PLATE
7	SAFETY THERMOSTAT
11	CAVITY DRAIN PIPE
12	HOT FUMES EXHAUST CHIMNEY
13	ACCESSORIES CONNECTION
22	WATER PUMP INLET
27	COOLING AIR OUTLET

## ITALIANO - DISEGNI

2	MORSETTIERA ALIMENTAZIONE
3	MORSETTO EQUIPOTENZIALE
6	TARGHETTA DATI TECNICI
7	TERMOSTATO DI SICUREZZA
11	SCARICO CAMERA DI COTTURA
12	USCITA FUMI CALDI
13	COLLEGAMENTO ACCESSORI
22	INGRESSO ACQUA POMPA
27	USCITA ARIA DI RAFFREDDAMENTO

## FRANCAIS - ENCOMBREMEN

2	BOITE A BORNES D'ALIMENTATION
3	SUPPORT BORNE EQUIPOTENTIELLE
6	PLAQUETTE SEGNALETIQUE
7	THERMOSTAT DE SECURITE
11	SORTIE DE L'EAU RACCORD
12	SORTIE DES FUMEEES CHAUDES
13	JONCTION DES ACCESSOIRES
22	ENTREE D'EAU POMPE
27	SORTIE D'EAU DE REFROIDISSEMENT

## ESPAÑOL - DISEÑOS

2	CAJA DE CONEXION
3	SEDE BORNE EQUIPOTENCIAL
6	TARJETA DE CARACTERISTICAS TECNICAS
7	TERMOSTATO DE SEGURIDAD
11	DESCARGA CAMARA DE COCCION
12	SALIDA HUMOS CALIENTES
13	CONEXION ACCESORIOS
22	INGRESO AGUA A LA BOMBA
27	SALIDA DEL AIRE DE ENFRIAMIENTO

## DEUTSCH - ZEICHNUNGEN

2	ZULEITUNGSKLEMMLEISTE
3	GLEICHPOTENTIELLE KLAMMER
6	TYPENSCHILD
7	SICHERHEITSTHERMOSTAT
11	WASSERAUSLASS GEWINDE
12	ABZUGSHAUBE
13	ZUBEHÖRTEILENVERBINDUNG
22	WASSEREINZUG DER PUMPE
27	KÜHLLUFTAUSTRITT

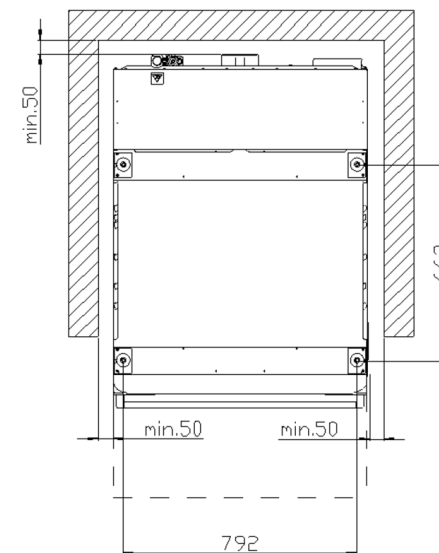
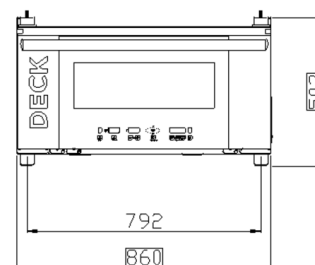
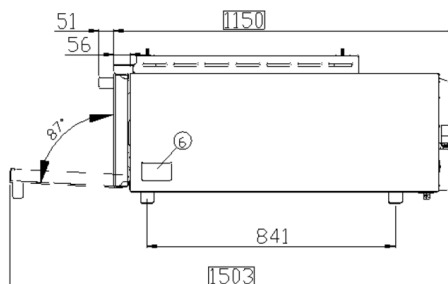
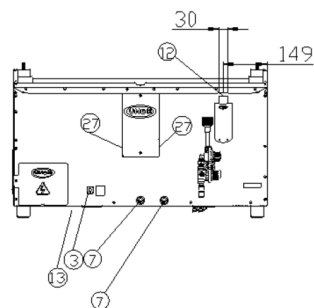

# MOD:XEBDC-02EU-D



ENGLISH	WIRING DIAGRAMS
μP	DOOR MICROSWITCH
C	ELECTRIC CONDENSER
E	WATER SOLENOID VALVE
H	OVEN LIGHT
K	CONTACTOR
M	MOTOR
PR	REFIT PUSH BUTTON
SF	CAVITY TEMPERATURE CONTROL PROBE
SP	POWER CARD
TS	SAFETY THERMOSTAT

ITALIANO	SCHEMI ELETTRICI
μP	MICRO INTERRUOTORE PORTA
C	CONDENSATORE
E	ELETTROVALVOLA ACQUA
H	LUCE FORNO
K	TELERUTTORE
M	MOTORE
PR	PULSANTE RIARMO
SF	SONDA CAMERA
SP	SCHEDA POTENZA
TS	TERMOSTATO SICUREZZA

FRANCAIS	SCHEMAS ELECTRIQ
μP	MICRO INTERRUPTEUR DE PORTE
C	CONDENSATEUR
E	ELECTROVANNE
H	LAMPE DU FOUR
K	TELERUPTEUR
M	MOTEURS DES TURBINES
PR	BOUTON POUSSOIR DU REMISE EN MARCHÉ
SF	SONDE DE LA CHAMBRE
SP	FICHE DE PUISSANCE
TS	THERMOSTAT DE SECURITE'

ESPAÑOL	ESQUEMAS ELECTRI
μP	MICRO INTERRUPTOR PUERTA
C	CONDENSADOR
E	ELECTROVALVULA
H	LUZ HORNO
K	TELERRUPTOR
M	MOTOR
PR	PULSADOR DE RE-ACTIVACION
SF	SONDA CAMARA
SP	PLACA DE POTENCIA
TS	TERMOSTATO DE SEGURIDAD

DEUTSCH	SCHALTPLAN
μP	TÜRKONTAKTSCHALTER
C	KONDENSATOR
E	ELEKTROVENTIL
H	BELEUCHTUNG
K	RELAIS
M	MOTOR
PR	WIEDERHERSTELLUNGSTASTE
SF	GARRAUMTEMPERATURFÜHLER
SP	POWERPLATINE
TS	SICHERHEITS THERMOSTAT

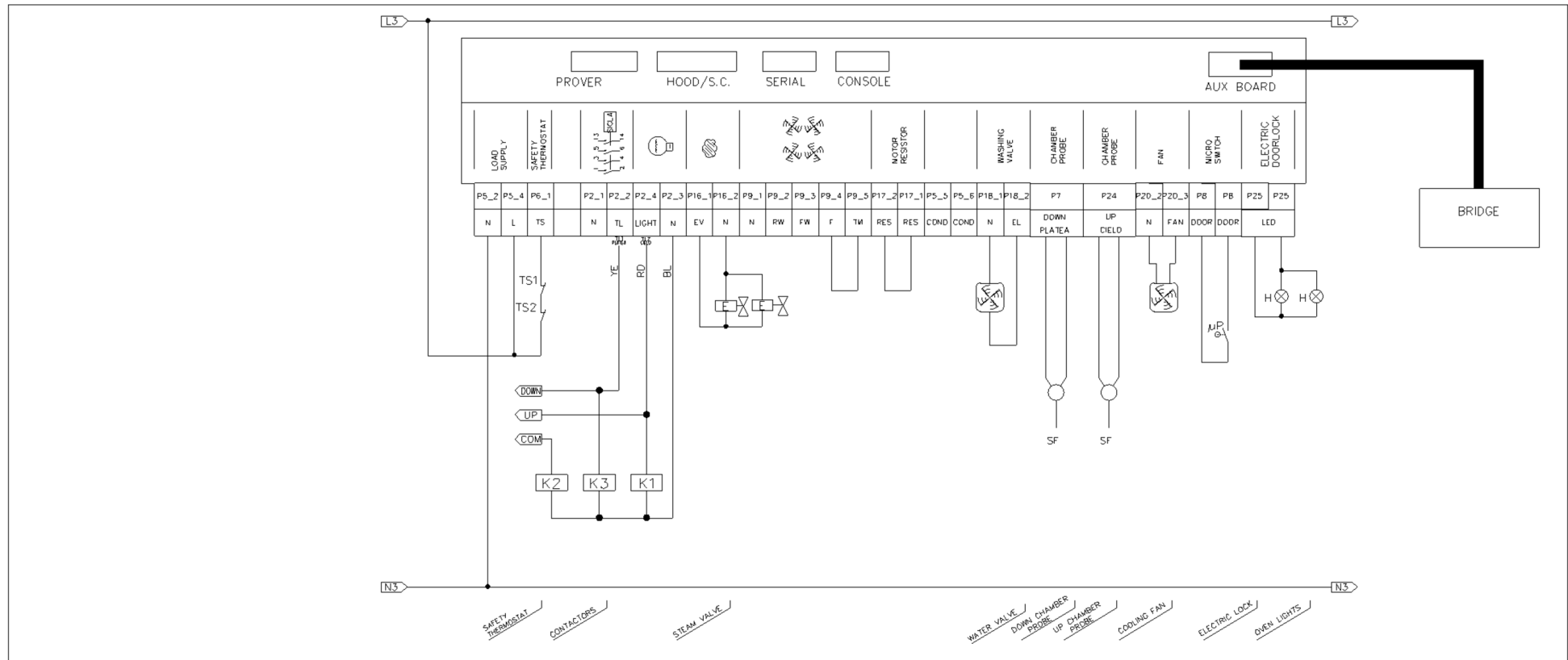

# MOD:XEBDC-02EU-D



ENGLISH		WIRING DIAGRAMS
K	CONTACTOR	
MO	TERMINAL BOARD	
R	HEATING ELEMENT	

ITALIANO		SCHEMI ELETTRICI
K	TELERUTTORE	
MO	MORSETTIERA	
R	RESISTENZA	

FRANCAIS		SCHEMAS ELECTRIQ
K	TELERUPTEUR	
MO	BOITE A BORNES	
R	RESISTANCE	

ESPAÑOL		ESQUEMAS ELECTRI
K	TELERRUPTOR	
MO	CAJA CONEXIONES-REGLETA	
R	RESISTENCIA	

DEUTSCH		SCHALTPLAN
K	RELAYS	
MO	KLEMMLEISTE	
R	HEIZELEMENT	

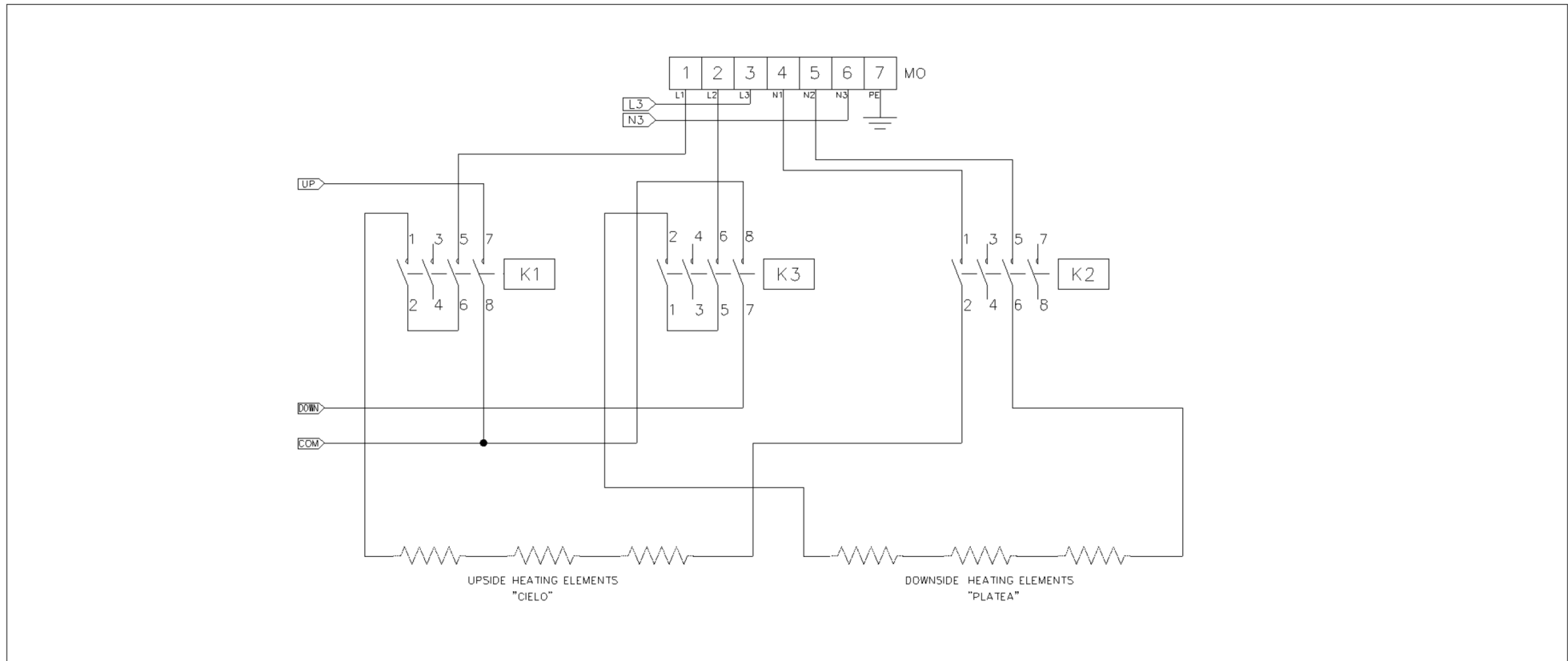

## POWER SUPPLY - CONNECTION DIAGRAM

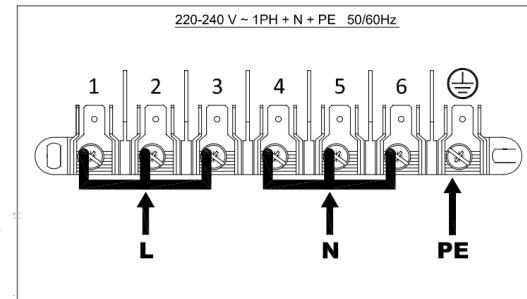
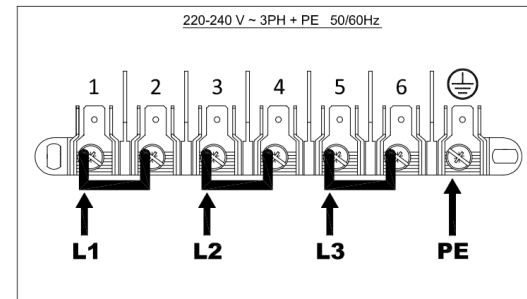
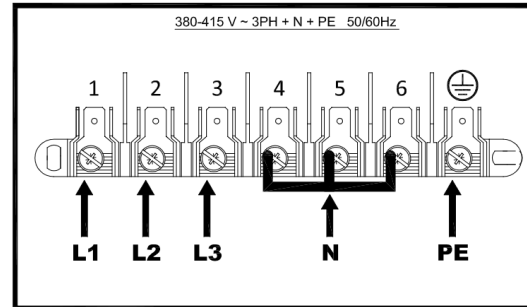

Ⓢ Unox non si assume la responsabilità per collegamenti elettrici non contemplati nel presente foglio dati tecnici.  
 Ⓢ Unox does not take any responsibility for electrical connections not mentioned in this data sheet.  
 Ⓢ Unox übernimmt keine Verantwortung für die elektrischen Anschlüsse nicht in diesem technischen Datenblatt angegeben.  
 Ⓢ Unox n'assume pas la responsabilité pour les connexions électriques qui ne sont pas prévues par cette fiche de données techniques.  
 Ⓢ Unox no assume ninguna responsabilidad por las conexiones eléctricas no figuradas en este folio de datos técnicos.  
 Ⓢ Unox não se responsabiliza por conexões elétricas não contempladas nos dados técnicos do presente documento.